

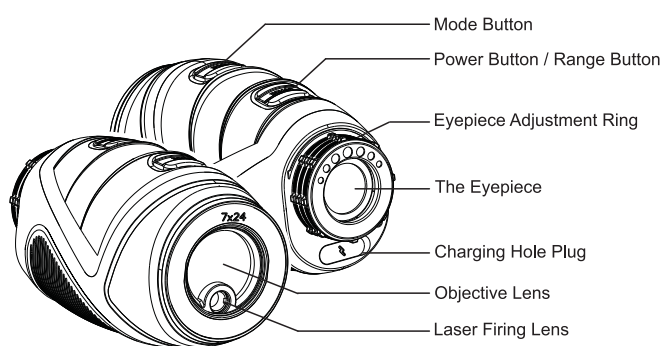

Operation Manual

01 Parts Of Device



02 Product Parameters

Distance Range	5m~1000m
Measuring Accuracy	±1m
Angle Range	±60°
Angle Accuracy	±1°
Laser Type	905nm (Class 1 laser)
Magnification	7X
Object Lens Size	24 mm
Effective Eyepiece	16 mm
Exit Pupil Diameter	3 mm
Field Angle	6.6°
Battery	lithium battery (800mAh)
Weight	172 g
Dimensions	105*47*59 (mm)
Operating Temperature	-10°C~ +60°C

List of Accessory:

Laser Rangefinder(1pc)	Carry Bag(1pc)	Box(1pc)
Operation Manual(1pc)	Charging line (1 pc)	Lens Cloth(1pc)

03 Display Description

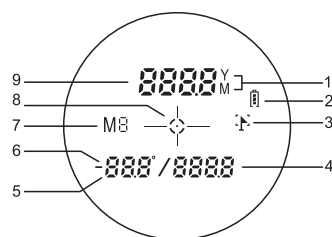

- | | |
|-----------------------|-------------------------------|
| 1, Unit : meter /yard | 6, Minus Sign |
| 2, Electricity Icon | 7, Measurement Mode Code Icon |
| 3, Flag Pole Icon | 8, Target Icon |
| 4, Slope Distance | 9, Distance / Flag Distance |
| 5, Angle | |

04 Basic Operations

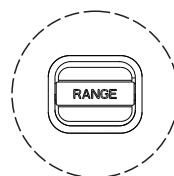

Power ON / OFF

Power ON:
Short press the Power button [RANGE] to turn on.

Power OFF:
The machine will shut down automatically after 8 seconds if no any operations.



Unit Switch

Press and hold the [MODE] button for 2 seconds to switch the units in turn, and release the [MODE] button to keep the switched unit;

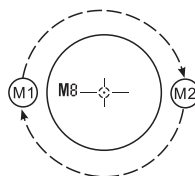

Mode Switch

Short press the [MODE] button to switch between modes. All modes are displayed on the screen in a loop, and the mode is selected when you release the [MODE] button.

05 General operation



Single Measurement:

Short press the [RANGE] button to start the single measurement.

- Take M2 mode as an example

Target display :

-when the [RANGE] button is pressed ● : Flash once



Continuous Measurement:

Press the [RANGE] button and keep over 2 seconds, the measured distance value displayed alternately on the screen, and the target sign "•" will be showed on the screen until release the [RANGE] button.

Target display :

-when the [RANGE] button is pressed ● : Always bright

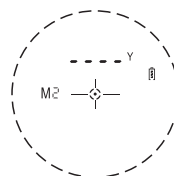

Failure Measurement :

If the measure fails, the data on the screen will be displayed as: "----"

Press the [RANGE] button to remeasure.

06 Battery

This machine uses a built-in rechargeable lithium battery.

If the power is insufficient, please charge in time;
The power indicator shows red means charging, the indicator shows green is means charging completed.

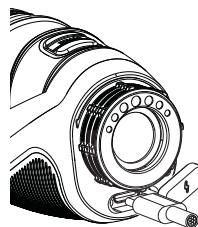

Battery specifications: built-in 3.7v lithium battery

Battery life: charge and discharge 800 times;

Power adapter: 5V/0.8A
(accessories without power adapters)

Power Indicator

Matters Needing Attention:

1. Please use the standard charging cable for charging.
2. When the power is insufficient, please charge it in time.
3. Do not overcharge.
4. After charging, please disconnect the power supply in time.



Type-C Power Cord

07 Golf Mode

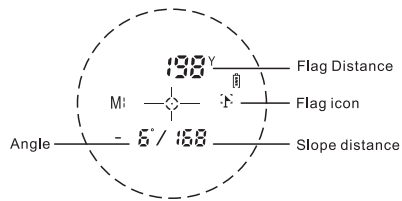

Operation Method:

Short press the [RANGE] button and release it after aiming at the flagpole, then scan both sides of the flagpole (flag part) with the target center (After the target is locked, this sign flashes twice, and the product body vibration prompt), the Flag distance is displayed at the top of the screen, the Slope distance and Angle will be displayed at the bottom of the screen.

- ★ The angle range of slope correction is within $\pm 20^\circ$.
- ★ The mode don't supports continuous measurement function.
- ★ When the "-" sign is displayed in front of the angle, it means that the angle is the depression angle. Angle range $\pm 60^\circ$.

08 Golf Slope Correction Use Scenes

You could get the slope correction distance using AB distance and angle according to golf track formula.

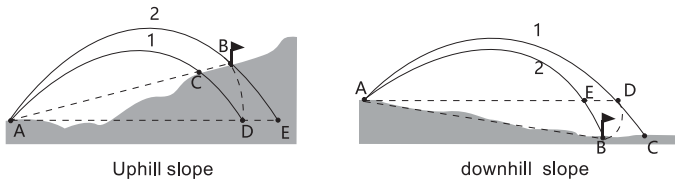

When uphill, the hitting distance is far

$AB=AD$, if you want hit to B point, you would hit like parabola 2 instead parabola 1 when uphill. The distance the ball travels should be the distance between AE points.

When downhill, the hitting distance is shorter

$AB=AD$, if you want hit to B point, you would hit like parabola 2 instead parabola 1 when downhill. The distance the ball travels should be the distance between AE points.

09 Range Mode

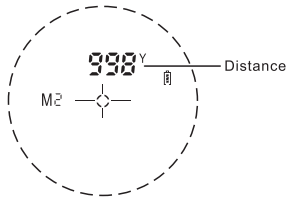

Operation Method:

In the mode, short press the button after targeting, the distance would be displayed on the top of the screen.

- ★ The mode supports continuous measurement function.
- ★ Within 100 (m/yard), the Distance data with decimal point.
- Beyond 100 (m/yard), All data without decimal point.

10 General Usage Scenes Description

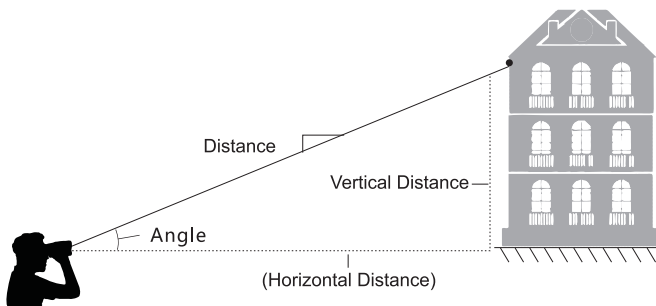

11 Precaution

1 Warning: Laser safety

To avoid any harm to eyes, please do not look at the laser emission aperture after pressing the POWER / RANGE button.

2 Transportation

Please add enough cushioning material to the box to avoid unnecessary damage during transport.

3 Storage

Please keep the product out of reach of children. Don't put it on a high and unsteady place to prevent falling on the ground. Do not place the product in a high temperature environment or it may cause damage of the products.

4 Maintenance

Please do not touch the lens with your fingers to avoid damage to the glass coating. In the case of extreme changes in temperature, the lens surface will be covered by fog, please don't use it before the fog evaporates. Please clean the lens only with a soft cloth and nothing else when there are smudges on the lens.

5 Disposal

The package and discarded products should be recycled or disposed properly in accordance with local laws.

6 Measurement Considerations

The laser range finder is suitable for measuring highly reflective objects (such as highway's Road sign), moderately reflective objects (such as building's wall) and low reflectivity objects (such as tree, golf, utility pole, animal etc.) When reflectivity is reduced, the effective operating range will be reduced accordingly.



7 Factors that influence ranging capability

Target reflectivity

Generally speaking, the higher the reflectivity of the object, the better the ranging ability. For example, for moderate reflectivity object, the measuring range is 1500M, and it can up to 1800M for high reflectivity object, but may be only 600M for low reflectivity one. (It may fail to measure the target that can hardly create diffuse reflection, such as water surface.)

Target shape

When a target is too small or uneven, the ranging ability will decrease.

Measuring angle

The ranging ability would be better if the measured object is vertical with the laser emission's direction. It's possible that the measuring range cannot meet the ranging ability specified in the manual under some extreme conditions.

Environment factor

The environment factors including sunshine intensity, the concentration of water vapor in the air and suspended particles (such as rain, fog, snow, fog, haze, etc.)

The range ability of the product defined under the following conditions

- 1) The measurement target is with moderate reflectivity, such as building walls.
- 2) The measured object is vertical with laser emission direction.
- 3) The weather condition is sunny but not direct sunlight.
- 4) The reflection area is large than $2m \times 2m$.